

Strobe Wire Guard Damage Stoppers®

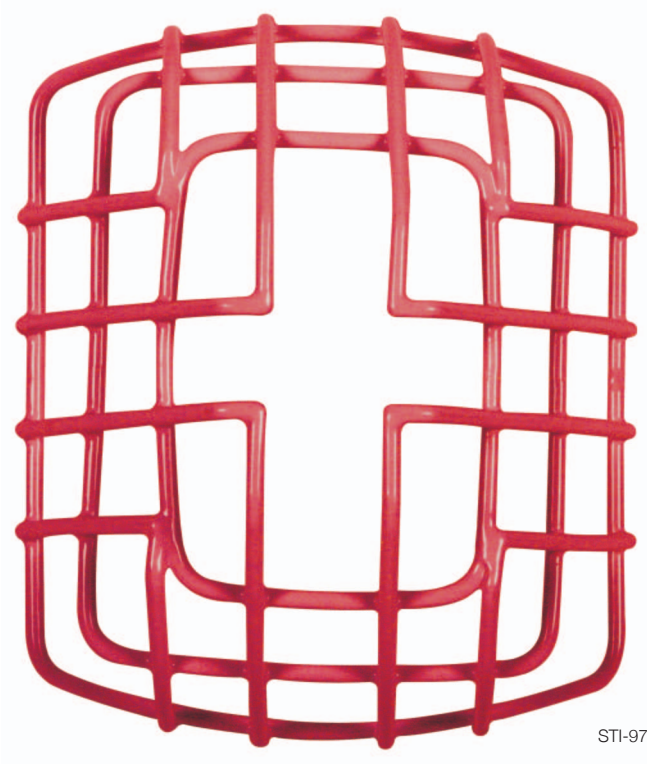

STI-9705-R

PRODUCT OVERVIEW

Here is an excellent way to protect strobe units against both vandalism and accidental damage. These wire guards provide maximum protection for System Sensor SPECTRAAlert Advance series strobe notification appliances. Constructed of tough, 9-gauge steel wire that is coated with corrosion resistant red or white polyester, these guards can take hard knocks in stride.

BACKED BY A LIFETIME GUARANTEE

As all STI protective covers, these guards are backed by a lifetime guarantee against breakage in normal use. Installation and servicing is easy with all screws and anchors provided. This Stopper is highly recommended for areas where abuse is severe or it is imperative that strobe units continue to operate.

FEATURES

- Offers protection against vandalism and accidental damage SPECTRAAlert strobe units.
- Constructed of tough 9-gauge steel wire.
- Installation is fast and simple with screws and anchors provided.
- Simple removal for maintenance.
- Coated with corrosion resistant polyester.
- Guaranteed for a lifetime against breakage in normal use.

Strobe Wire Guard Damage Stoppers®

Dimensions and Technical Information

MODELS AVAILABLE

- STI-9705** Strobe Wire Guard Damage Stopper® - White
- STI-9705-R** Strobe Wire Guard Damage Stopper® - Red
- STI-9708** Strobe Wire Guard Damage Stopper® - White
- STI-9708-R** Strobe Wire Guard Damage Stopper® - Red
- STI-9711** Strobe Wire Guard Damage Stopper® - White
- STI-9714** Strobe Wire Guard Damage Stopper® - White

WARRANTY

Lifetime guarantee against breakage in normal use.

MODEL	HEIGHT	WIDTH	DEPTH
STI-9705			
STI-9705-R	7.40 in. (188mm)	6.15 in. (156mm)	3.39 in. (86mm)
STI-9708			
STI-9708-R	7.49 in. (190mm)	6.74 in. (171mm)	6.09 in. (155mm)
STI-9711	8.26 in. (210mm)	8.26 in. (210mm)	3.54 in. (90mm)
STI-9714	8.55 in. (271mm)	8.55 in. (271mm)	6.23 in. (158mm)

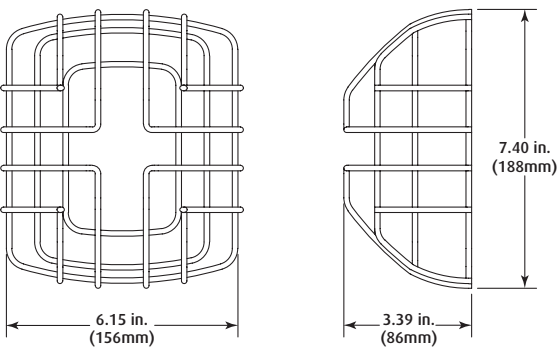

STI-9705

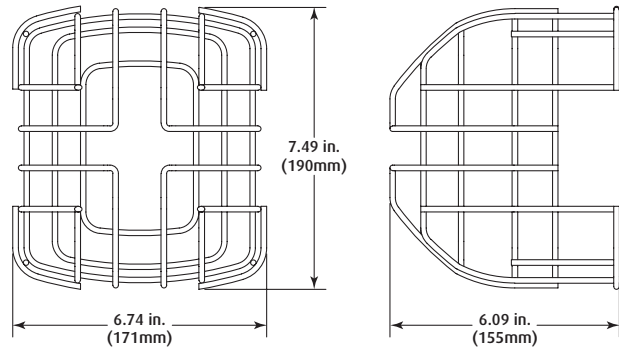

STI-9708

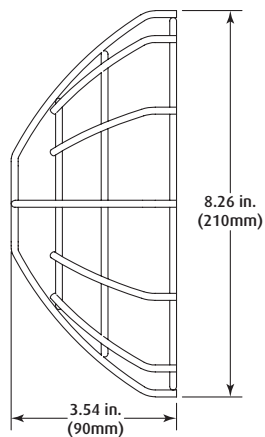

STI-9711

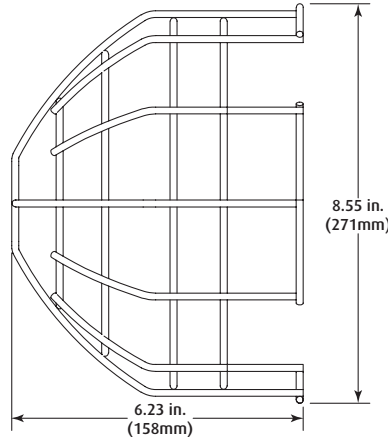

STI-9714



Safety Technology International, Inc.

2306 Airport Road
Waterford, Michigan
48327, USA

Tel: 248-673-9898
Fax: 248-673-1246
Tollfree: 800-888-4784
info@sti-usa.com
www.sti-usa.com

Unit 49G Pipers Road
Park Farm Industrial Estate
Redditch, Worcestershire
B98 0HU England

Tel: 44 (0) 1527 520 999
Fax: 44 (0) 1527 501 999
Free: 0800 085 1678 (UK)
www.sti-europe.com