



May 1, 2004

DN-6066 • J-89A

MDL & MDLW Sync Modules for the SpectrAlert® Series

Section: Audio/Visual Devices

GENERAL

The Sync•Circuit module synchronizes SpectrAlert® strobes at 1 Hz and horns at temporal 3 over a single pair of wires. Patented module technology also allows the silencing of horns on horn/strobe models over a pair of wires.

Application Flexibility. The Sync•Circuit module is designed to power and synchronize either two 3-amp circuits wired in Class B or one 3-amp circuit powered as Class A. Should more than two zones require synchronization, additional modules can be added by interconnecting the “slave” input and output terminals between modules.

Additional Capabilities. The Sync•Circuit module is also designed to generate temporal 3 tone for System Sensor’s Multi-Alert and PA400 Mini-Alert sounders. Existing installations can be upgraded to comply with NFPA 72.

MODULE CONFIGURATION

Each MDL module has the capability of connecting two Style Y (Class B) circuits or one Style Z (Class A) circuit.

The NAC output(s) from the panel are connected to the zone inputs of the MDL module and the zone output(s) from the MDL module are connected to the notification loop(s). Supervision is accomplished in the module by a direct connection between the zone input and the zone output of each of the two zone circuits connected to the normal end-of-line device. The FACP “sees” the EOL device through the MDL module. When either or both outputs (zones 1 & 2) from the module are wired to the SpectrAlert products, the horns and strobes in both zones will be synchronized.

The MDL module can be configured so that more than two zones can be synchronized by the interconnection of the slave input and output (see **Application Examples**).

SPECIFICATIONS

Voltage range: DC or full-wave-rectified; 11 to 30 volts.
NOTE: Supply voltage range at 12 volts, 11 to 17 VDC; at 24 volts, 21 to 30 VDC.

Maximum load on loop: 3 amps.

Current: chart at right.

Operating temperature: 0°C to 49°C (32°F to 120°F).



California State Fire Marshal
7300-1209:179

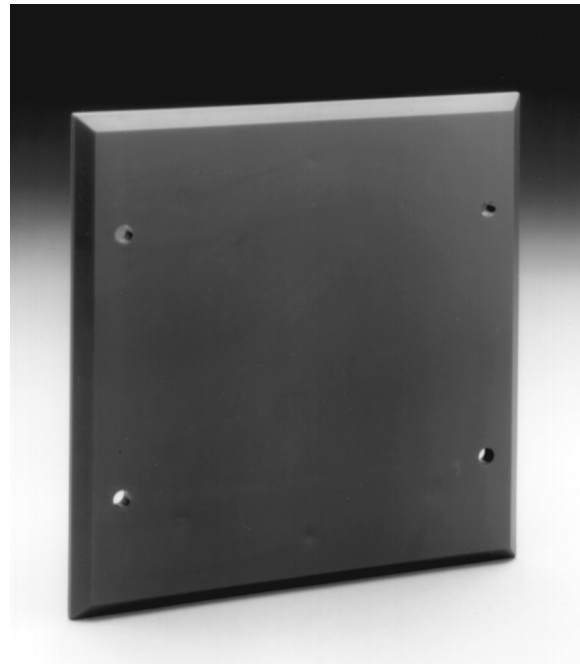

The MDL Module

SPECIAL CONSIDERATIONS

NOTE: The MDL Module is factory-set with the trouble contacts in the open state. These contacts may close during shipping. Approximately two seconds after power-up, these contacts will open.

Voltage	Current Draw					
	Average Current(mA)		Peak Current(mA)		In-rush Current(mA)	
	DC	FWR	DC	FWR	DC	FWR
12	10	12	30	31	87	122
24	11	15	35	37	198	262

NOTIFIER® is a Honeywell company.

This document is not intended to be used for installation purposes. We try to keep our product information up-to-date and accurate. We cannot cover all specific applications or anticipate all requirements. All specifications are subject to change without notice. For more information, contact NOTIFIER. Phone: (203) 484-7161 FAX: (203) 484-7118

12 Clintonville Road, Northford, Connecticut 06472



APPLICATION EXAMPLES

Temporal Coding on Multi-Alert and PA400 (Non-SpectrAlert Horns)

- Program module to provide temporal coding by inserting jumper plug per instructions.
- Connect only sounders producing a continuous tone to the module zone output(s).

CAUTION!

Strobes cannot be used on a module providing temporal coding to horns! Strobes must be wired for independent operation.

NOTE: Temporal jumper should be inserted across both pins only on non-SpectrAlert products that are to be powered for temporal sound output.

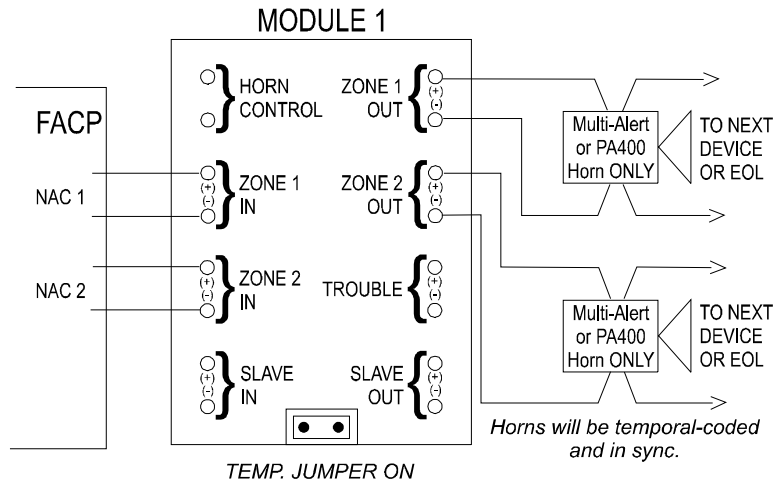

Synchronize SpectrAlert Horns and Strobes

ZONE 1 INPUT	This input powers the MDL Module. This input must have voltage present from the FACP before anything will work. This also supplies voltage to Zone 1 output.
ZONE 2 INPUT	This input only supplies voltage to Zone 2 output. NOTE: If Zone 1 input is not powered, the notification devices attached to the Zone 2 output will not be allowed.
HORN CONTROL	This input enables the horns on the SpectrAlert notification appliances. Voltage present means horns are enabled. No voltage present means horns are disabled.
SLAVE IN	Connects to Master MDL Module slave out.
SLAVE OUT	Connects to Slave MDL slave in.

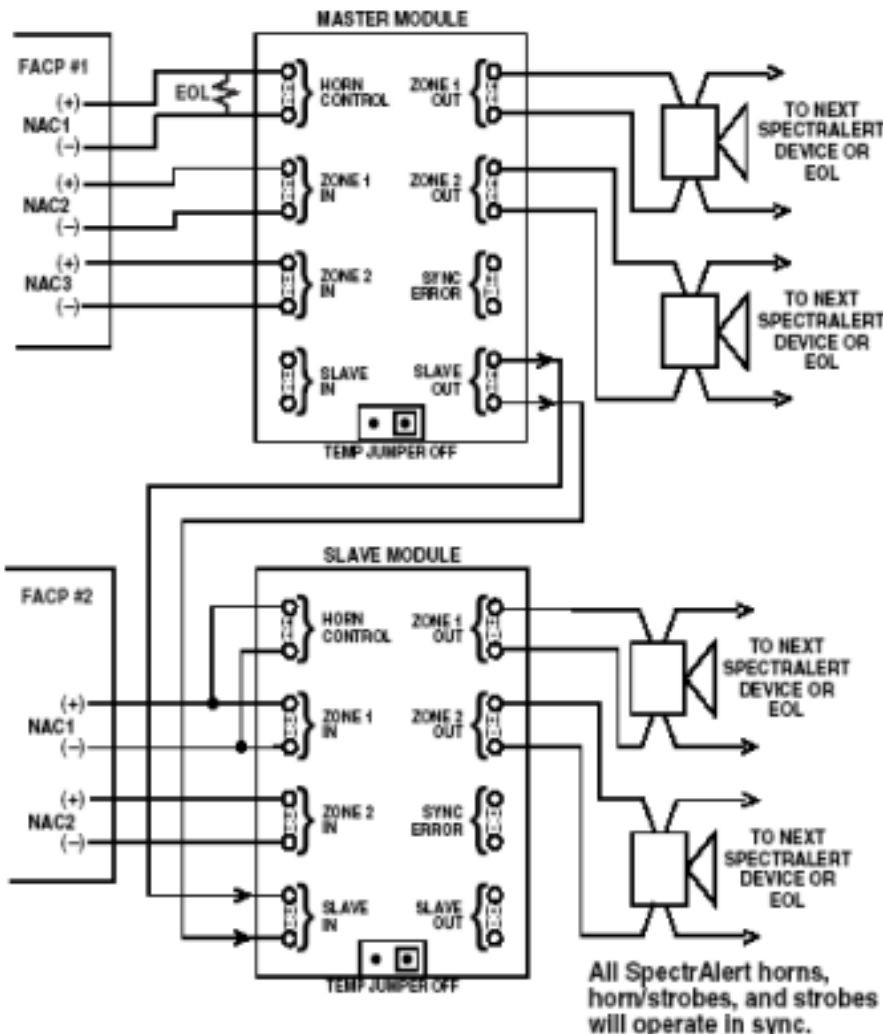

Synchronize SpectrAlert Horns and Strobes

- Each module can power two three-amp circuits wired in Class B, or one three-amp circuit powered as Class A.
- Each module will synchronize two zones.
- Additional modules can be added and may be synchronized to all other modules by interconnecting the "slave" input and output terminals between modules.

Controlling Sounder On/Off Over Two Wires Using Module Horn Control

- Connect the current source to the horn control input. If a zone output is used for the source, you must use an EOL on the horn control input terminal.
- When multiple modules are used, the horn control circuits can be wired in parallel. If wired in parallel and a zone output is used from panel, use an EOL on the last module for supervision.

ZONE 1 INPUT	This input powers the MDL Module. This input must have voltage present from the FACP before anything will work. This also supplies voltage to Zone 1 output.
ZONE 2 INPUT	This input only supplies voltage to Zone 2 output. NOTE: If Zone 1 input is not powered, the notification devices attached to the Zone 2 output will not be allowed.
HORN CONTROL	This input enables the horns on the SpectrAlert notification appliances. Voltage present means horns are enabled. No voltage present means horns are disabled.
SLAVE IN	Connects to Master MDL Module slave out.
SLAVE OUT	Connects to Slave MDL slave in.

Horns Silenced Over Two-Wire Circuit

- 1) Any mix of SpectrAlert horns/strobes or strobe-only devices is acceptable.
- 2) Horn Control connects to interruptible power source.

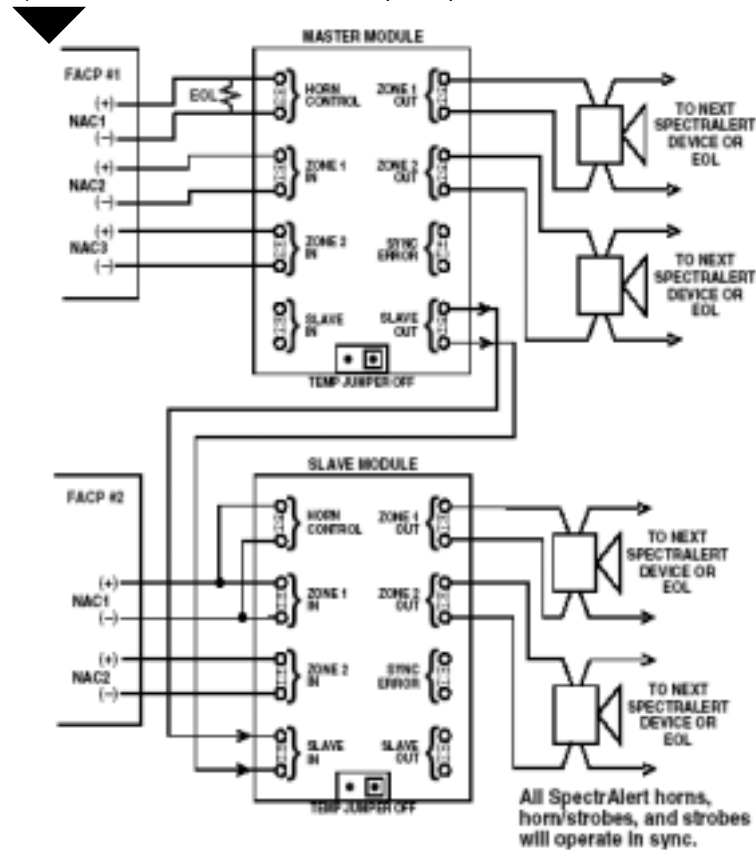

NOTES:

- 1) Any mix of SpectrAlert horn/strobe, strobe-only, or horn-only devices is allowable for Zone 1.
- 2) No devices or horn-only are allowed on Zone 2. If no devices are installed on Zone 2, terminate EOL resistor at horn control terminal.

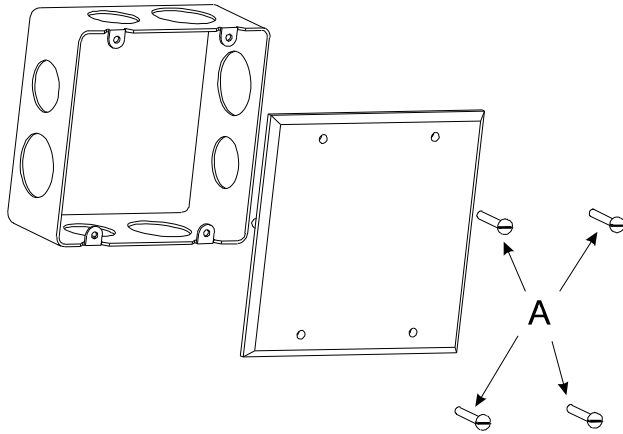

MOUNTING DIAGRAM

- 1) Complete field wiring.
- 2) Mount unit to 4-11/16" backbox with screws ("A").



LIMITATIONS OF HORNS/STROBES

The horn and/or strobe will not work without power. The horn/strobe gets its power from the fire/security panel monitoring the alarm system. If power is cut off for any reason, the horn/strobe will not provide the desired audio or visual warning.

The horn may not be heard. The loudness of the horn meets (or exceeds) current Underwriters' Laboratories standards. However, the horn may not alert a sound sleeper or one who has recently used drugs or has been drinking alcoholic beverages. The horn may not be heard if it is placed on a different floor from the person in hazard or if placed too far away to be heard over the ambient noise such as traffic, air conditioners, machinery or music appliances that may prevent alert persons from hearing the alarm. The horn may not be heard by persons who are hearing impaired.

The signal strobe may not be seen. The electronic visual warning signal uses an extremely reliable xenon flash tube. It flashes at least once every three seconds and exceeds current Underwriters' Laboratories standards for private mode viewing. The visual warning signal is suitable for direct viewing and must be installed within an area where it can be seen by building occupants. The strobe must not be installed in direct sunlight or areas of high light intensity (over 60 footcandles) where the visual flash might be disregarded or not seen. The strobe may not be seen by the visually impaired and is not intended to meet American Disabilities Act (ADA) requirements.

The signal strobe may cause seizures. Individuals who have positive photic response to visual stimuli with seizures, such as persons with epilepsy, should avoid prolonged exposure to environments in which strobe signals, including this strobe, are activated.

The signal strobe cannot operate from coded power supplies. Coded power supplies produce interrupted power. The strobe must have an uninterrupted source of DC power in order to operate correctly. System Sensor recommends that the horn and signal strobe always be used in combination so that the risks from any of the above limitations are minimized.

PRODUCT LINE INFORMATION

MDL Sync module for use with SpectrAlert Series, **red**.

MDLA Sync module for use with SpectrAlert Series, red, **for Canada**

MDLW Same as above, **white**.

MDLWA Same as above, white, **for Canada**

Three-Year Limited Warranty

System Sensor warrants these horns/strobes to be free from defects in materials and workmanship under normal use and service for a period of three years from date of manufacture. For complete warranty information, contact System Sensor.