

Wheelock NS/NH Series

NS Series Horn Strobes NH Series Horns



Audio/Visual Devices

General

The Wheelock Series NS Horn Strobe Appliances will satisfy virtually all requirements for indoor, wall mount applications.

The Series NH Horn and the horn portion of the Series NS include a selectable continuous horn tone or temporal pattern (Code 3) with selectable dBA settings of 90 or 95 dBA.

Strobe options include 1575cd or Wheelock’s patented Multi-Candela strobe with field selectable candela settings of 15/30/75/110cd.

These versatile Horn Strobe Appliances may be synchronized when used in conjunction with the Wheelock SM or DSM Sync Modules or a Power Supply with the Wheelock patented Sync Protocol. Additionally, the audible may be silenced while maintaining strobe activation.

All models of the Series NS and NH are designed for maximum performance, reliability and cost-effectiveness while meeting or exceeding the latest requirements of NFPA 72/ANSI 117.1/UFC and UL Standards 1971 and 464 as well as meeting ADA requirements concerning photosensitive epilepsy.

Features

- Field selectable Candela settings 15/30/75/110cd (24 VDC Multi-Candela models) or 1575cd in 12 or 24 VDC.
- Selectable Continuous Horn or Temporal (Code 3).
- 2 selectable dBA settings of 90 and 95 dBA in both tones.
- 12 and 24 VDC models with UL “Regulated Voltage” using filtered DC or unfiltered VRMS input voltage.
- Patented Universal Mounting Plate.
- Wall mount.
- ADA/NFPA/UFC/ANSI compliant.
- Complies with OSHA 29, Part 1910.165.
- NH Horn is selectable 12 or 24 VDC in 1 unit.
- Synchronize with Wheelock SM or DSM Sync Module or the Power Supply with built-in Sync Protocol.
- Patent Pending Universal Mounting Plate for single-gang, double-gang 4” (10.16c m) square, or 100 mm European backboxes, or Wheelock’s SHBB shallow surface backbox.
- Fast installation with IN/OUT screw terminals using #12 to #18 AWG wires.

General Notes

- Strobes are designed to flash at 1 flash per second minimum over their “Regulated Voltage Range.” Note that NFPA 72 specifies a flash rate of 1 to 2 flashes per second and ADA Guidelines specify a flash rate of 1 to 3 flashes per second.
- All candela ratings represent minimum effective Strobe intensity based on UL Standard 1971.
- Series NS Strobe products are listed under UL Standard 1971 for indoor use with a temperature range of 32°F to 120°F (0°C to 49°C) and maximum humidity of 93% (± 2%).
- Series NH Horns are listed under UL Standard 464 for audible signal appliances (indoor use only).

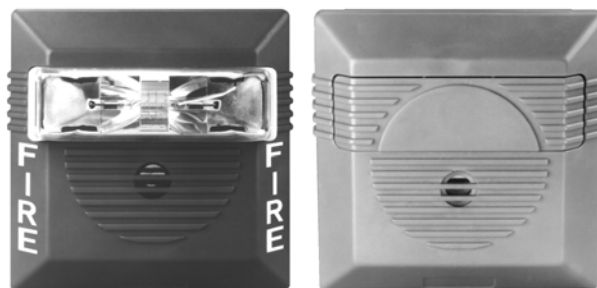

NS Horn Strobe

NH Horn



Multi-Candela Indicator
(bottom of Strobe Lens)

6601photo1.jpg; 6601photo2.jpg; 6601photo3.jpg

- “Regulated Voltage Range” is the newest terminology used by UL to identify the voltage range. Prior to this change, UL used the terminology “Listed Voltage Range.”



WARNING: PLEASE READ THESE SPECIFICATIONS AND ASSOCIATED INSTALLATION INSTRUCTIONS CAREFULLY BEFORE USING, SPECIFYING OR APPLYING THIS PRODUCT. FAILURE TO COMPLY WITH ANY OF THESE INSTRUCTIONS, CAUTIONS OR WARNINGS COULD RESULT IN IMPROPER APPLICATION, INSTALLATION AND/OR OPERATION OF THESE PRODUCTS IN AN EMERGENCY SITUATION, WHICH COULD RESULT IN PROPERTY DAMAGE, AND SERIOUS INJURY OR DEATH TO YOU AND/OR OTHERS.

Table 1: Ratings Per UL Standard 1971

Model	Input Voltage VDC	Regulated Voltage Range VDC/FWR	Strobe Candela (CD)
NS-24MCW	24	16.0-33.0	15/30/75/110
NS-241575W	24	16.0-33.0	15 (75 on axis)

Description	Volume	Reverberant dBA @ 10ft per UL 464		Anechoic dBA @ 10ft	
		12VDC	24VDC	12VDC	24VDC
		Continuous Horn	High	83	87
	Low	76	81	84	90
Code 3 Horn	High	79	82	89	95
	Low	72	76	84	90

NS-24MCW with High (95 dBA) Setting				
Voltage	15cd	30cd	75cd	110cd
16.0 VDC	.077	.113	.195	.268
24.0 VDC	.065	.087	.134	.174
33.0 VDC	.069	.085	.117	.134
NS-24MCW with Low (90 dBA) Setting				
Voltage	15cd	30cd	75cd	110cd
16.0 VDC	.070	.106	.188	.261
24.0 VDC	.052	.072	.126	.158
33.0 VDC	.045	.060	.097	.114

NS-241575W		
Voltage	High (95) dBA	Low (90) dBA
16.0 VDC	.120	.116
24.0 VDC	.094	.093
33.0 VDC	.102	.078

Voltage	High (95) dBA	Low (90) dBA
16.0 VDC	.019	.017
24.0 VDC	.028	.022
33.0 VDC	.039	.027

Model Number	Input Voltage (VDC)	Average Mean Current @ 24 VDC	Mounting Options
SM-12/24-R	24	.028	W
DSM-12/24-R	24	.035	W

NOTE: SM Sync Module is rated for 3.0 amperes @ 24 VDC. DSM Sync Module is rated for 3.0 amperes per circuit. The maximum number of interconnected DSM Modules is twenty (20).

* Average RMS Current is per UL average RMS method and Average Mean Current is per UL average mean method. NH models use average mean current. For rated in Rush and Peak current across UL Listed voltage range for both filtered DC and VRMS (FWR), see installation instructions.

Series NS/NH 24 VDC		Audible	Wall Mount Strobe Models				
		NH-12/24	NS-241575W	NS-24MCW			
		@24VDC	15/75cd	15cd	30cd	75cd	110cd
High (95) dBA	24VDC	.044	.104	.074	.107	.184	.244
Low (90) dBA	24VDC	.018	.096	.066	.101	.177	.232
Series NS/NH 12 VDC		Audible	Wall Mount	** RMS current ratings are per UL average RMS method. UL max current rating is the maximum RMS current within the listed voltage range (16-33V for 24V units). For strobes, the UL max current is usually at the minimum listed voltage (16V for 24V units). For audibles, the max current is usually at the listed voltage (33V for 24V units). For unfiltered FWR ratings, see installation instructions.			
		NH-12/24	Aud/Strobe				
		@12VDC	NS-121575W				
High (95) dBA	12VDC	.021	.220				
Low (90) dBA	12VDC	.012	.210				



WARNING: CONTACT WHELOCK FOR THE CURRENT INSTALLATION INSTRUCTIONS (P83983) SERIES NS-24MCW, (P84234) SERIES NS-12 AND 24 VDC SINGLE CANDELA MODELS, (P83600) SERIES NH AND “GENERAL INFORMATION” SHEET (P82380) ON THESE PRODUCTS. THESE DOCUMENTS UNDERGO PERIODIC CHANGES. IT IS IMPORTANT THAT YOU HAVE CURRENT INFORMATION ON THE PRODUCTS. THESE MATERIALS CONTAIN IMPORTANT INFORMATION THAT SHOULD BE READ PRIOR TO SPECIFYING OR INSTALLING THESE PRODUCTS, INCLUDING:

- TOTAL CURRENT REQUIRED BY ALL APPLIANCES CONNECTED TO SYSTEM SECONDARY POWER SOURCES.
- FUSE RATINGS ON NOTIFICATION APPLIANCE CIRCUITS TO HANDLE PEAK CURRENTS FROM ALL APPLIANCES ON THOSE CIRCUITS.
- COMPOSITE FLASH RATE FROM MULTIPLE STROBES WITHIN A PERSON’S FIELD OF VIEW.
- ADDING, REPLACING OR CHANGING APPLIANCES OR CHANGING CANDELLA SETTINGS WILL AFFECT CURRENT DRAW. RECALCULATE CURRENT DRAW TO INSURE THAT THE TOTAL AVERAGE CURRENT AND TOTAL PEAK REQUIRED BY ALL APPLIANCES DO NOT EXCEED THE RATED CAPACITY OF THE POWER SOURCES OR FUSES.
- THE VOLTAGE APPLIED TO THE PRODUCTS MUST BE WITHIN THEIR “REGULATED VOLTAGE RANGE.”
- INSTALLATION OF 110 CANDELA STROBE PRODUCTS IN SLEEPING AREAS.
- INSTALLATION IN OFFICE AREAS AND OTHER SPECIFICATION AND INSTALLATION ISSUES.
- THESE APPLIANCES ARE NOT DESIGNED TO BE USED ON CODED SYSTEMS IN WHICH THE APPLIED VOLTAGE IS CYCLED ON AND OFF.
- FAILURE TO COMPLY WITH THE INSTALLATION INSTRUCTIONS OR GENERAL INFORMATION SHEETS COULD RESULT IN IMPROPER INSTALLATION, APPLICATION, AND/OR PROPERTY DAMAGE AND SERIOUS INJURY OR DEATH TO YOU AND/OR OTHERS.
- CONDUCTOR SIZE (AWG), LENGTH AND AMPACITY SHOULD BE TAKEN INTO CONSIDERATION PRIOR TO DESIGN AND INSTALLATION OF THESE PRODUCTS, PARTICULARLY IN RETROFIT INSTALLATIONS.

Wiring Diagrams

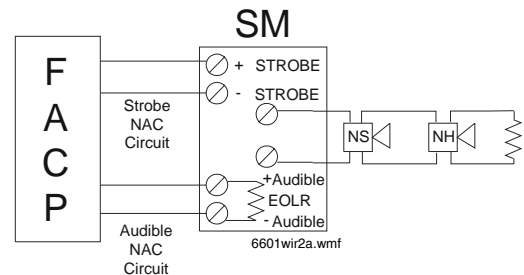
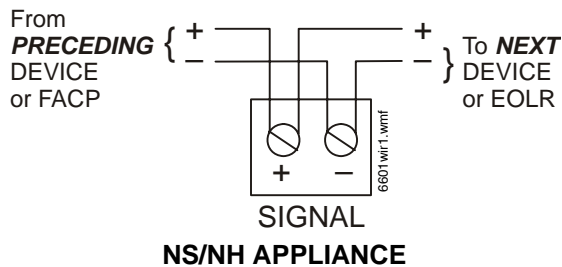

NS AND NH APPLIANCES SYNCHRONIZED WITH SM MODULE SINGLE CLASS “B” NAC CIRCUIT WITH AUDIBLE SILENCE FEATURE

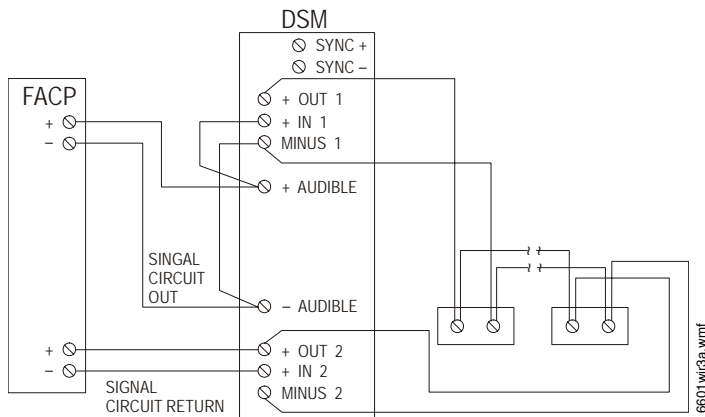

NS AND NH APPLIANCES SYNCHRONIZED WITH DSM MODULE DUAL CLASS “A” NAC CIRCUIT WITH NO AUDIBLE SILENCE FEATURE

NOTE: NS/NH must be set on Code 3 horn tone to achieve synchronized temporal (Code 3) tone. Refer to installation instructions (P83983, P83600 respectively).

NOTE: For detail using SM or DSM Sync Module refer to data sheet S3000 or installation instructions P83123 for SM and P83177 for DSM.

Architectural/Engineering Specifications

The audible/visual notification appliances shall be Wheelock Series NS Horn Strobe appliances and Series NH Horn appliances or approved equals. The Series NS appliances shall meet and be listed for UL Standard 1971 (Emergency Devices for the Hearing-Impaired for Indoor Fire Protection Service). The Series NH Horn shall be UL Listed under Standard 464 (Fire Protective Signaling). The horn strobe shall be listed for indoor use and shall meet the requirements of FCC Part 15 Class B. All inputs shall be compatible with standard reverse polarity supervision of circuit wiring by the Fire Alarm Control Panel (FACP).

The audible portion of the appliance shall have a minimum of two (2) field selectable settings for dBA levels (90 and 05 dBA) and shall have a choice of continuous or temporal (Code 3) audible outputs.

The strobe portion of the appliance shall produce a flash rate of one (1) flash per second over the Regulated Voltage Range and shall incorporate a Xenon flashtube enclosed in a rugged Lexan lens. The Series NS shall be of low current design. Where wall mount, Multi-Candela appliances are specified, the strobe intensity shall never have field selectable settings and shall be rated per UL Standard 1971 for 15/30/75/110 candela. The selector switch for selecting the candela setting shall be tamper resistant. The 1575 candela strobe shall be specified when 15 candela UL Standard 1971 Listing with 75 candela on-axis is required (e.g. ADA compliance).

Ordering Information

Model	Strobe Candela	Non-Sync	Sync w/ SM, DSM	24 VDC	12 VDC	2 Wire	Mounting Options	Agency Approvals				
								UL	MEA	CSFM	FM	BFP
NS-24MCW-FR	15/30/75/110	X	X	X	-	X	B,D,E,F,G,H,J,N,O,R,X	X	X	X	X	X
NS-24MCW-FW	15/30/75/110	X	X	X	-	X	B,D,E,F,G,H,J,N,O,R,X	X	X	X	X	X
NS-241575W-FR	15 (75 on axis)	X	X	X	-	X	B,D,E,F,G,H,J,N,O,R,X	X	X	X	X	X
NH-12/24-R	12V, 24V	X	X	X	X	X	B,D,E,F,G,H,J,N,O,R,X	X	X	X	X	X

When synchronization is required, the appliance shall be compatible with Wheelock's SM, DSM Sync Modules or a Power Supply with Wheelock's built-in patented Sync Protocol. The strobes shall not drift out of synchronization at any time during operation. If the Sync Module or Power Supply fails to operate (i.e. contacts remain closed), the strobes shall revert to a non-synchronized flash-rate. The appliance shall also be designed so that the audible signal may be silenced while maintaining strobe activation.

The Series NS Horn Strobes and NH Horn shall incorporate a patented Universal Mounting Plate that shall allow mounting to a single-gang, double-gang, 4 inch square, and 100 mm European backboxes, or the SHBB Surface Backbox. If required, an NATP (Notification Appliance Trimplate) shall be provided.

All notification appliances shall be backward compatible.

Listings and Approvals

These listings and approvals apply to the modules specified in this document. In some cases, certain modules or applications may not be listed by certain approval agencies, or listing may be in progress. Consult factory for listing status.

- **ULC Listed:** E5946
- **ULC Listed:** CS 243, CS 356
- **CSFM:** 7125-0785:142
- **MEA:** 151-92-E
- **FM Approved**

©2008 by Honeywell International Inc. All rights reserved. Unauthorized use of this document is strictly prohibited.



This document is not intended to be used for installation purposes. We try to keep our product information up-to-date and accurate. We cannot cover all specific applications or anticipate all requirements. All specifications are subject to change without notice.



For more information, contact Notifier. Phone: (203) 484-7161, FAX: (203) 484-7118. www.notifier.com