

SpectrAlert® Advance

Selectable Output CHRA, CHWA Chimes and CHSRA, CHSWA Chime/Strobes



Audio/Visual Devices

General

System Sensor SpectrAlert® Advance selectable-output chimes and chime/strobes are private-mode notification appliances used to alert trained personnel to investigate possible emergency situations and to take appropriate action. Security guard and nurse workstations are ideal locations for chime products.

SpectrAlert Advance chimes and chime/strobes are rich with features guaranteed to cut installation times and maximize profits. The SpectrAlert Advance series of notification appliances is designed to simplify your installations, with features such as: plug-in designs, instant feedback messages to ensure correct installation of individual devices, and seven field-selectable candela settings for chime/strobes.

More specifically, when installing Advance products, first attach a universal mounting plate to a four-inch (10.16 cm) square, four-inch octagonal, single-gang, or double-gang junction box.

Then, connect the notification appliance circuit wiring to the SEMS terminals on the mounting plate.

Finally, attach the chime or chime/strobe to the mounting plate by inserting the product's tabs in the mounting plate's grooves. The device will rotate into position, locking the product's pins into the mounting plate's terminals. The device will temporarily hold in place with a catch until it is secured with a captive mounting screw.

SpectrAlert Advance products allow you to choose:

- 12 or 24 volts.
- At 24 volts, 15, 15/75, 30, 75, 95, 110, or 115 candela by way of rear-mounted slide-switch and front-view window.
- Chime tones and volume by way of rotary switch.

Features

- Plug-in design.
- Shorting spring on mounting plate for pre-installation continuity check.
- Captive mounting screw.
- Torx screw for tamper resistance.
- Field-selectable candela settings: 15, 15/75, 30, 75, 95, 110, 115.
- Automatic selection of 12- or 24-volt operation at 15 and 15/75 candela.
- Minimal intrusion into the backbox.
- Rotary switch for tone selection.
- Two volume settings.
- Electrically compatible with existing SpectrAlert products.

Engineering Specifications

SpectrAlert Advance chimes and chime/strobes shall mount to a standard 4.0" x 4.0" x 1.5" backbox, 4.0" octagonal backbox, single-gang 2.0" x 4.0" x 1.875" backbox, or double-gang backbox. A universal mounting plate shall be used for mounting products. The notification appliance circuit wiring shall terminate at the universal mounting plate. Also, SpectrAlert Advance products, when used with the

7089pho1.tif



Chime (CHW)

P2F-P-rgb.bmp



Chime/Strobe (CHSR)

Sync•Circuit™ Module accessory, shall be powered from a non-coded notification appliance circuit output and shall operate on a nominal 12 or 24 volts. When used with the Sync•Circuit Module, 12-volt rated notification appliance circuit outputs shall operate between 9 and 17.5 volts; 24-volt rated notification appliance circuit outputs shall operate between 17 and 33 volts. Indoor SpectrAlert Advance products shall operate between 32°F and 120°F from a regulated DC, or full-wave-rectified, unfiltered power supply. Chime/strobes shall have field-selectable candela settings of 15, 15/75, 30, 75, 95, 110, and 115.

CHIME/STROBE COMBINATION

The chime/strobe shall be a System Sensor SpectrAlert Advance Model _____ listed to UL/ULC 1638 and UL/ULC 464. The chime/strobe shall comply with the Americans with Disabilities Act requirements for visible signaling appliances, flashing at 1 Hz over the strobe's entire operating voltage range. The strobe light shall consist of a xenon flash tube and associated lens/reflector system. The chime shall have two audibility options and an option to switch between a temporal three-pattern and a non-temporal (continuous) pattern. These options are set by a multiple position switch.

SYNCHRONIZATION MODULE

The module shall be a System Sensor Sync•Circuit _____ listed to UL/ULC 464 and shall be approved for fire protective service. The module shall synchronize SpectrAlert strobes at 1 Hz and chimes at Temporal 3. Also, while operating the strobes, the module shall silence the chimes on chime/strobe models over a single pair of wires. The module shall mount to a 4.688" x 4.688" x 2.125" backbox. The module shall also control two Style Y (Class B) circuits or one Style Z (Class A) circuit. The module shall synchronize multiple zones. Daisy-chaining two or more synchronization modules together will synchronize all the zones they control. The module shall not operate on a coded power supply.

Operating Specifications

- **Standard operating temperature:** 32°F to 120°F.
- **Humidity range:** 10% to 93% non-condensing (indoor products).
- **Strobe flash rate:** 1 flash per second.

- **Nominal voltage:** regulated 12 VDC/FWR or regulated 24 VDC/FWR.
- **Operating voltage range:** 8 V to 17.5 V (12 V nominal); or 16 V to 33 V (24 V nominal). **NOTE:** CHS products will operate at 12 V nominal only for 15 cd and 15/75 cd.
- **Input terminal wire gauge:** 12 to 18 AWG.
- **Chime/strobe dimensions (including lens):** 5.6" H x 4.7" W x 2.5" D.
- **Chime dimensions:** 5.6" H x 4.7" W x 1.3" D.

Agency Listings and Approvals

The listings and approvals below apply to SpectrAlert Advance Selectable Output Chimes and Chime/Strobes. In some cases, certain modules may not be listed by certain approval agencies, or listing may be in process. Consult factory for latest listing status.

- **UL/ULC** Listed: file S4011.
- **FM** approved.
- **MEA** approved: file 452-05-E.
- **CSFM** approved: file 7125-1653:188 (CHSR, CHSW); file 7135-1653:189 (CHR, CHW).

Ordering Information

CHR: Chime, red.

CHRA: Same as above with ULC listing.

CHW: Chime, white.

CHWA: Same as above with ULC listing.

CHSR: Chime/strobe, red.

CHSRA: Same as above with ULC listing.

CHSW: Chime/strobe, white.

CHSWA: Same as above with ULC listing.

BBS-2: Backbox skirt, wall, red.

BBS-2A: Same as above with ULC listing.

BBSW-2: Backbox skirt, wall white.

BBSW-2A: Same as above with ULC listing.

Current Draw, UL Maximum (mA RMS)

Input, Pattern, dB Out	8 – 17.5 Volts		16 – 33 Volts						
	15 cd	15/75 cd	15 cd	15/75 cd	30 cd	75 cd	95 cd	110 cd	115 cd
DC, 1-Second Chime, HIGH	131	142	65	76	94	160	185	207	213
DC, 1-Second Chime, LOW	131	142	64	75	92	157	183	203	212
DC, 1/4-Second Chime, HIGH	129	142	66	75	95	159	184	205	212
DC, 1/4-Second Chime, LOW	129	142	64	74	91	155	181	204	211
DC, Temporal Chime, HIGH	125	142	64	74	91	156	181	205	211
DC, Temporal Chime, LOW	129	141	65	75	92	155	180	200	209
DC, 5-Second Whoop, HIGH	133	145	70	81	99	165	189	210	217
DC, 5-Second Whoop, LOW	130	143	66	77	95	160	186	206	214
DC, One-Time Chime	127	141	64	76	93	156	182	203	210
FWR, 1-Second Chime, HIGH	128	150	72	82	98	158	183	202	210
FWR, 1-Second Chime, LOW	127	150	71	81	97	157	182	202	210
FWR, 1/4-Second Chime, HIGH	129	149	72	82	99	160	183	203	211
FWR, 1/4-Second Chime, LOW	128	149	71	81	97	154	179	196	205
FWR, Temporal Chime, HIGH	128	148	71	81	97	157	179	199	206
FWR, Temporal Chime, LOW	125	147	71	81	97	156	180	200	206
FWR, 5-Second Whoop, HIGH	136	152	84	93	110	170	193	212	220
FWR, 5-Second Whoop, LOW	132	150	77	86	102	161	184	203	214
FWR, One-Time Chime	127	147	72	82	97	157	181	200	210

Tone Selection

Chime tone selection is accomplished by using the rotary switch on the back of the product. The current draw and sound measurements for various chime tones are listed below.

Chime Current Draw, UL Maximum (mA RMS)

Sound Pattern	dB	8 – 17.5 Volts		16 – 33 Volts	
		DC	FWR	DC	FWR
1-Second Chime	HIGH	34 mA	50 mA	58 mA	51 mA
1-Second Chime	LOW	30 mA	51 mA	51 mA	54 mA
1/4-Second Chime	HIGH	34 mA	51 mA	50 mA	50 mA
1/4-Second Chime	LOW	31 mA	51 mA	50 mA	52 mA
Temporal Chime	HIGH	30 mA	50 mA	48 mA	54 mA
Temporal Chime	LOW	30 mA	47 mA	50 mA	51 mA
5-Second Whoop	HIGH	32 mA	52 mA	34 mA	54 mA
5-Second Whoop	LOW	30 mA	40 mA	34 mA	52 mA
One Test Chime	HIGH	48 mA	49 mA	50 mA	50 mA

Chime Patterns

Setting	Repetition Rate	dB Out
1	1-Second Chime	HIGH
2	1-Second Chime	LOW
3	1/4-Second Chime	HIGH
4	1/4-Second Chime	LOW
5	Temporal Chime	HIGH
6	Temporal Chime	LOW
7	5-Second Whoop	HIGH
8	5-Second Whoop	LOW
9	One Test Chime	HIGH

Sound Output (dBA), Chime and Chime/Strobe

Switch Setting	Sound Pattern	dB	8 – 17.5 Volts		16 – 33 Volts	
			DC	FWR	DC	FWR
1	1-Second Chime	HIGH	58 dBA	59 dBA	61 dBA	61 dBA
2	1-Second Chime	LOW	53 dBA	54 dBA	55 dBA	55 dBA
3	1/4-Second Chime	HIGH	63 dBA	64 dBA	66 dBA	66 dBA
4	1/4-Second Chime	LOW	58 dBA	59 dBA	60 dBA	60 dBA
5	Temporal Chime	HIGH	62 dBA	64 dBA	68 dBA	69 dBA
6	Temporal Chime	LOW	55 dBA	57 dBA	60 dBA	60 dBA
7	5-Second Whoop	HIGH	68 dBA	71 dBA	75 dBA	77 dBA
8	5-Second Whoop	LOW	62 dBA	64 dBA	67 dBA	68 dBA
9	One Test Chime	HIGH	57 dBA	55 dBA	61 dBA	57 dBA

SpectrAlert Advance Chime/Strobe Dimensions

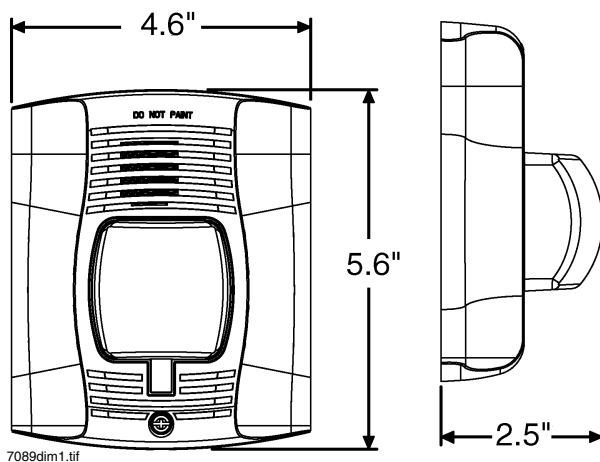

Sync•Circuit™ is a trademark and **Notifier®, SpectrAlert®** and **System Sensor®** are registered trademarks of Honeywell International Inc.
©2010 by Honeywell International Inc. All rights reserved. Unauthorized use of this document is strictly prohibited.



This document is not intended to be used for installation purposes.
We try to keep our product information up-to-date and accurate.
We cannot cover all specific applications or anticipate all requirements.
All specifications are subject to change without notice.



Made in the U.S. A.

For more information, contact Notifier. Phone: (203) 484-7161, FAX: (203) 484-7118.
www.notifier.com